

**Description**

These devices are n-channel, enhancement mode, power MOSFETs designed especially for high speed applications, such as switching power supplies, converters, AC and DC motor controls, relay and solenoid drivers and other pulse circuits.

- Low  $R_{DS(on)}$
- $V_{GS}$  Rated at  $\pm 20V$
- Silicon Gate for Fast Switching Speeds
- $I_{DSS}$ ,  $V_{DS(on)}$ , Specified at Elevated Temperature
- Rugged
- Low Drive Requirements
- Ease of Paralleling

TO-204AA

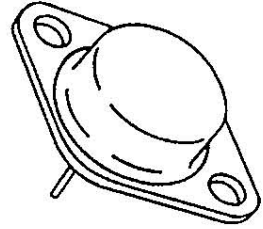

IS00020F

- IRF420
- IRF421
- IRF422
- IRF423

TO-220AB

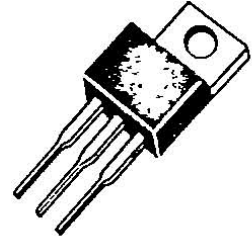

IS00010F

- IRF820
- IRF821
- IRF822
- IRF823
- MTP2N45
- MTP2N50

**Product Summary**

Part Number	$V_{DSS}$	$R_{DS(on)}$	$I_D$ at $T_c=25$	$I_D$ at $T_c=100$	Case Style
IRF420	500V	3.0 $\Omega$	2.5A	1.5A	TO-204AA
IRF421	450V	3.0 $\Omega$	2.5A	1.5A	
IRF422	500V	4.0 $\Omega$	2.0A	1.0A	
IRF423	450V	4.0 $\Omega$	2.0A	1.0A	
IRF820	500V	3.0 $\Omega$	2.5A	1.5A	TO-220AB
IRF821	450V	3.0 $\Omega$	2.5A	1.5A	
IRF822	500V	4.0 $\Omega$	2.0A	1.0A	
IRF823	450V	4.0 $\Omega$	2.0A	1.0A	
MTP2N45	450V	4.0 $\Omega$	3.0A	2.0A	
MTP2N50	500V	4.0 $\Omega$	3.0A	2.0A	

**Notes**

For information concerning connection diagram and package outline, refer to Section 7.



**IRF420-423/IRF820-823**  
**MTP2N45/2N50**  
**N-Channel Power MOSFETs**  
**3.0A, 450V/500V**

**Maximum Ratings**

Symbol	Characteristic	Rating IRF420/422 IRF820/822 MTP2N50	Rating IRF421/423 IRF821/823 MTP2N45	Unit
V <sub>DSS</sub>	Drain to Source Voltage 1	500	450	V
V <sub>DGR</sub>	Drain to Gate Voltage 1 R <sub>GS</sub> =20kΩ	500	450	V
V <sub>GS</sub>	Gate to Source Voltage	±20	±20	V
T <sub>J</sub> , T <sub>stg</sub>	Operating Junction and Storage Temperatures	-55 to +150	-55 to +150	
TL	Maximum Lead Temperature for Soldering Purposes, 1/8" From Case for 5s	275	275	

**Maximum Thermal Characteristics**

		IRF420-423/ IRF820-823	MTP2N45/2N50	
R <sub>θJC</sub>	Thermal Resistance, Junction to Case	3.12	1.67	/W
R <sub>θJA</sub>	Thermal Resistance, Junction to Ambient	30/80	80	/W
P <sub>D</sub>	Total Power Dissipation at T <sub>c</sub> =25	40	75	W
I <sub>DM</sub>	Pulsed Drain Current <sup>2</sup>	10	10	A

**Electrical Characteristics** (T<sub>c</sub>=25 unless otherwise noted)

Symbol	Characteristic	Min	Max	Unit	Test Conditions
<b>Off Characteristics</b>					
V <sub>(BR)DSS</sub>	Drain Source Breakdown Voltage <sup>1</sup> IRF420/422/820/822 MTP2N50	500		V	V <sub>GS</sub> =0V, I <sub>D</sub> =250μA
		450			
I <sub>DSS</sub>	Zero Gate Voltage Drain Current		250	μA	V <sub>DS</sub> =Rated V <sub>DSS</sub> , V <sub>GS</sub> =0V
			1000	μA	V <sub>DS</sub> =0.8 x Rated V <sub>DSS</sub> , V <sub>GS</sub> =0V, T <sub>c</sub> =125
I <sub>GSS</sub>	Gate-Body Leakage Current IRF420-423 IRF820-823/MTP2N45/50		±100	nA	V <sub>GS</sub> =±20V, V <sub>DS</sub> =0V
			±500		



**IRF420-423/IRF820-823**  
**MTP2N45/2N50**  
**N-Channel Power MOSFETs**  
**3.0A, 450V/500V**

**Electrical Characteristics (Cont.)** (Tc=25 unless otherwise noted)

Symbol	Characteristic	Min	Max	Unit	Test Conditions
<b>On characteristics</b>					
V <sub>GS(th)</sub>	Gate Threshold Voltage	2.0	4.0	V	I <sub>D</sub> =250μA, V <sub>DS</sub> =V <sub>GS</sub> I <sub>D</sub> =1.0mA, V <sub>DS</sub> =V <sub>GS</sub>
	IRF420-423/IRF820-823 MTP2N45/MTP2N50	2.0	4.5		
R <sub>DS(on)</sub>	Static Drain-Source On-Resistance 2			Ω	V <sub>GS</sub> =10V, I <sub>D</sub> =1.0A
	IRF420/421/820/821		3.0		
	IRF422/423/822/823 MTP2N45/50		4.0		
V <sub>DS(on)</sub>	Drain-Source On-Voltage2			V	V <sub>GS</sub> =10V; I <sub>D</sub> =2.0A
	MTP2N45/50		10	V	V <sub>GS</sub> =10V; I <sub>D</sub> =1.0A Tc=100
gfs	Forward Transconductance	1.0		S(Ω)	V <sub>DS</sub> =10V, I <sub>D</sub> =1.0A
<b>Dynamic Characteristics</b>					
Ciss	Input Capacitance		400	pF	V <sub>DS</sub> =25V, V <sub>GS</sub> =0V f=1.0MHz
Coss	Output Capacitance		100	pF	
Crss	Reverse Transfer Capacitance		40	pF	
<b>Switching Characteristics</b> (Tc=25, Figure 1,2) <sup>3</sup>					
td(on)	Turn-On Delay Time		40	ns	V <sub>DD</sub> =250V, I <sub>D</sub> =1.0A V <sub>GS</sub> =10V, R <sub>GEN</sub> =50 Ω R <sub>GS</sub> =50 Ω
tr	Rise Time		50	ns	
td(off)	Turn-Off Delay Time		60	ns	
tf	Fall Time		60	ns	
Qg	Total Gate Charge		15	nC	V <sub>GS</sub> =10V, I <sub>D</sub> =3.0A V <sub>DD</sub> =200V
<b>Symbol Characteristic Typ Max Unit Test Conditions</b>					
<b>Source-Drain Diode Characteristics</b>					
V <sub>SD</sub>	Diode Forward Voltage		1.4	V	I <sub>S</sub> =2.5A; V <sub>GS</sub> =0V
			1.3	V	I <sub>S</sub> =2.0A; V <sub>GS</sub> =0V
trr	Reverse Recovery Time	600		ns	I <sub>S</sub> =2.5A; dI <sub>S</sub> /dt=100A/μS

Notes

1. T<sub>J</sub>=+25 to +150
2. Pulse width limited by T<sub>J</sub>
3. Switching time measurements performed on LEM TR-58 test equipment.

### Typical Electrical Characteristics

Figure 1 Switching Test Circuit

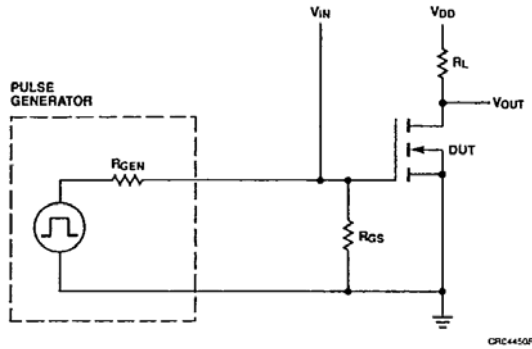

CRC4450F

Figure 2 Switching Waveforms

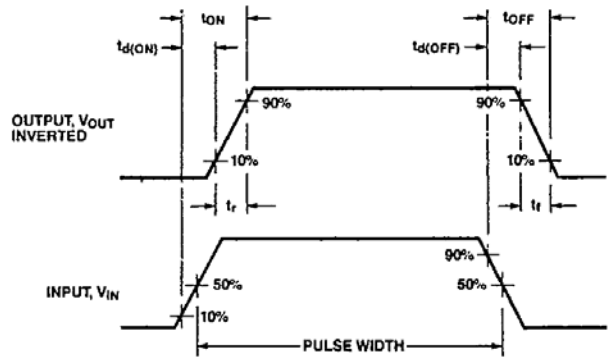

WF00600F

### Typical Performance Curves

Figure 3 Output Characteristics

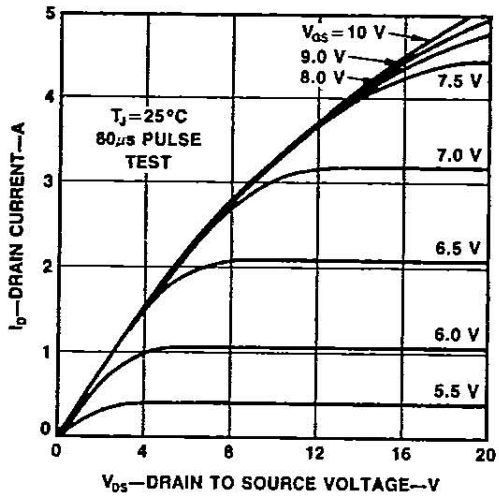

PC10720F

Figure 4 Static Drain to Source Resistance  
Vs Drain Current

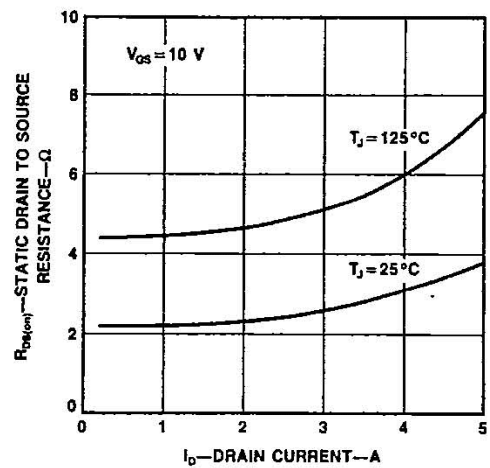

PC10730F

Figure 5 Transfer Characteristics

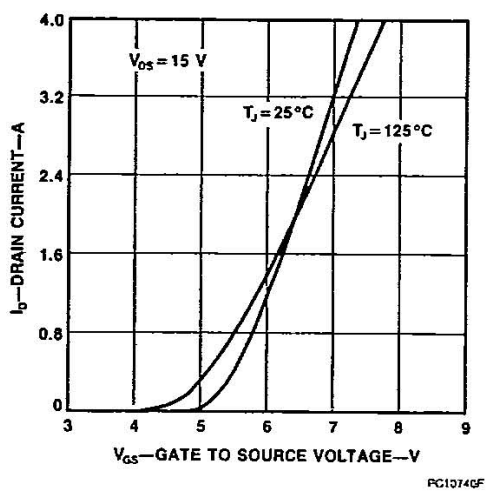

PC10740F

Figure 6 Temperature Variation of Gate to Source Threshold Voltage

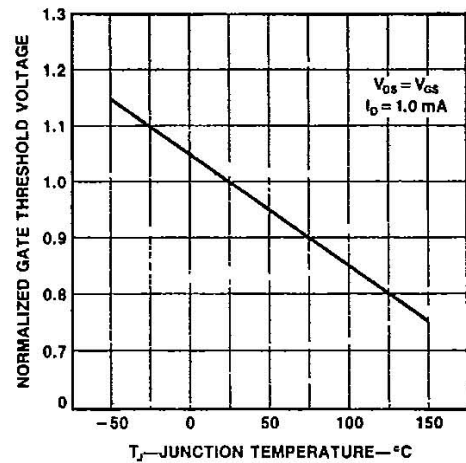

PC09841F

**Typical Performance Curves (Cont.)**

Figure 7 Capacitance vs Drain to Source Voltage

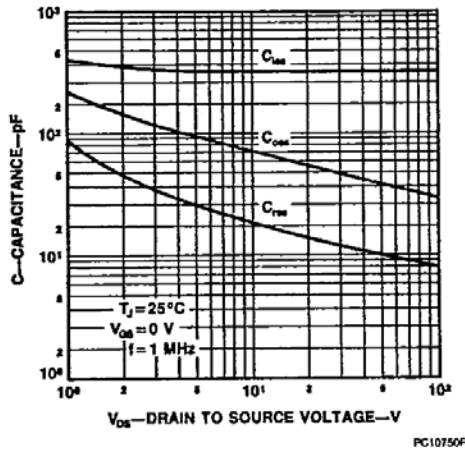

Figure 9 Forward Biased Safe Operating Area for IRF420-423 and IRF820-823

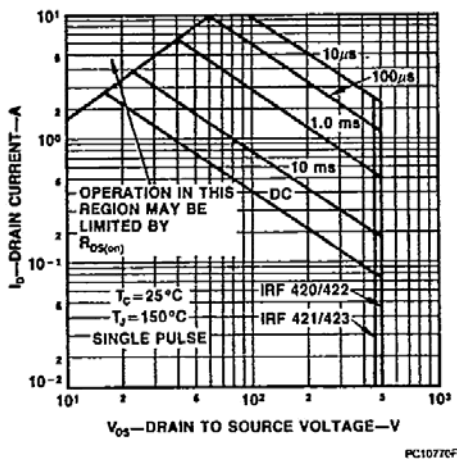

Figure 11 Forward Biased Safe Operating Area for MTP2N45/2N50

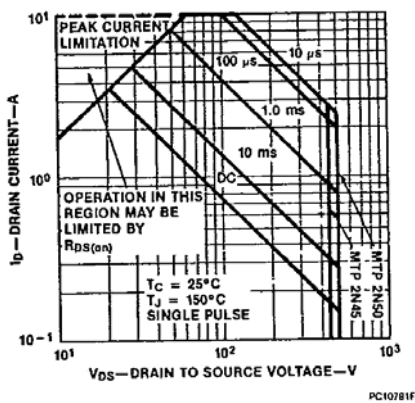

Figure 8 Gate to Source Voltage VS Total Gate Charge

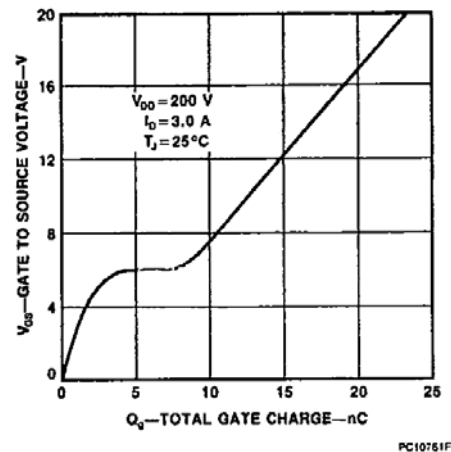

Figure 10 Transient Thermal Resistance vs Time for IRF420-423 and IRF820-823

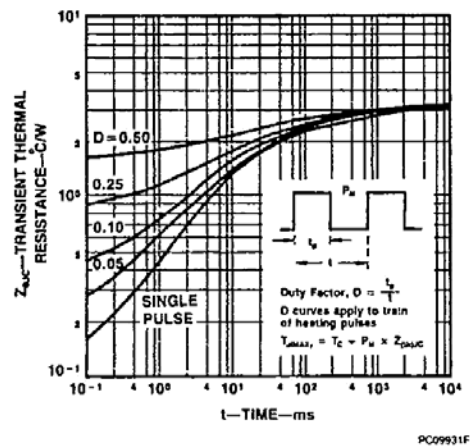

Figure 12 Transient Thermal Resistance vs time for MTP2N45/2N50

